

Datasheet

ORT and DORT Acoustic Release Transponders



Description

Oceanographic Release Transponders (ORTs) and Deep Oceanographic Release Transponders (DORTs) are tough, reliable acoustic releases designed for deployment in either 2,000 metres or 6,000 metres of water.

The units are commonly used to moor oceanographic instrument strings on the seabed for periods of up to 36 months. However, their compact size allows them to be easily incorporated into subsea instrument frames or installed on towfish and AUVs to enable ballast to be dropped in an emergency.

Standard features include a Safe Working Load of 1,275Kg (at 4:1) and a spring-assisted release mechanism. This type of release mechanism was originally developed by Sonardyne for navigation transponders supplied to the offshore industry of which there are now many thousands reliably in service around the world.

ORTs and DORTs are controlled using frequency band specific Lightweight Command Units (LCU) which comprises of a dunking transducer connected either to a spray-proof Psion or, via supplied software, to any PC. For security of operation, a special coding system provides protection against accidental release by noise and acoustic transmissions from other vessels.

Key Features

- Safe Working Load of 1,275Kg (Options for heavier loads)
- 2,000 Metre or 6,000 Metre depth rated options
- Highly reliable release mechanism
- Up to 3 years deployment
- Excellent corrosion resistance
- Compact and rugged design

Specifications

ORT and DORT Acoustic Release Transponders

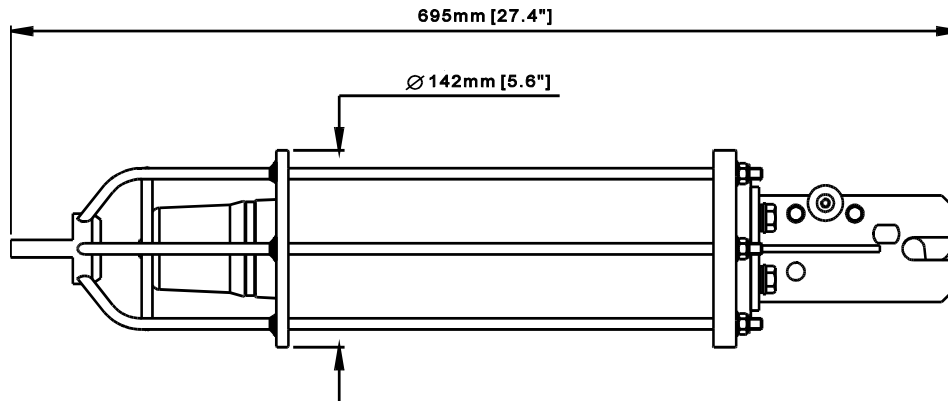

Feature		Type 7409	Type 7710
Depth Rating		2,000 Metres	6,000 Metres
Operating Frequency		MF (18-36kHz)	LF (7.5-15kHz)
Transducer Beamshape		Hemispherical	Hemispherical
Transmit Source Level (dB re 1µPa @1m)		186dB	190dB Alkaline, 184dB Lithium
Receive Threshold (dB re 1µPa)		<90dB	85dB
Safe Working Load (4:1) (Standard Release Mechanism)		1,275Kg	1,275Kg
Breaking Load		5,100Kg	5,100Kg
Max. Safe Release Load		1,700Kg	1,700Kg
Battery Life	Alkaline	9 months	9 months
	Lithium	24 months	24 months
	Long-Life Lithium	36 months	36 months
Shelf Life Battery	Alkaline	24 months	24 months
Disconnected @ 25°C	Lithium	84 months	84 months
Operating Temperature		-20 to + 45°C	-20 to + 45°C
Storage Temperature		-30 to + 70°C	-30 to + 70°C
Mechanical Construction		Aluminium Bronze, Stainless Steel	Aluminium Bronze, Stainless Steel
Dimensions (LxDia)		695mm (27.4") x 142mm (5.6")	695mm (27.4") x 142mm (5.6")
Weight in Air		22kg	22kg
Weight in Water		17kg	17kg
Deck Unit		Type 7663 MF LCU	Type 7667 LF LCU
Accessories		Parallel Release Kit Heavy Duty Release Frame	Parallel Release Kit Heavy Duty Release Frame