



OIL SPILL DETECTION MONITOR & ALARM

Patent Pending

**AUTOMATED
NON-CONTACT
OIL SPILL SENSOR**

**DETECT & CONTROL
OIL SPILLS IN REAL-TIME**

**CERTIFIED TO MEET
US EPA COMPLIANCE
STANDARDS**



**HIGHLY SENSITIVE
OPTICAL SHEEN
DETECTION**

**COST EFFECTIVE &
LOW MAINTENANCE**

SCADA / PLC COMPATIBLE

ALL WEATHER - 24 / 7 / 365

Slick Sleuth™ Autonomous Oil Spill Detection Stations (ADS) are used in a wide variety of industrial and environmental applications for remotely detecting oil spills. Should a spill occur, Slick Sleuth™ provides instant detection and notification; enabling users to contain spill and avert environmental damage, costly cleanup, and possible fines or regulatory penalties. The optical sensor detects small (micron-level) amounts of oil in real-time, and can be configured to automatically shut off pumps or valves, activate audio/visual alarms, and notify personnel and responders via computer display and/or telephone.

Slick Sleuth™ is designed and manufactured for deployment in rugged settings such as offshore, coasts, harbors, inland waterways, industrial spillways, sumps and separators, retention ponds, and other environments where oil spills are of concern. Slick Sleuth™ oil detectors are conveniently mounted **above the water** (typically installed 1-5 meters above target surface), facilitating ease of installation and operation, while eliminating problems inherent with other types of sensors that contact water/effluent directly. This simple above water (non contact) sampling method eliminates issues such as aquatic/marine bio-fouling or fouling due to oil or debris, making the system **trouble free to operate and maintain**. System is also perfectly suited for spill monitoring over ground, concrete, or wet/dry drainages, wherever spill detection is warranted.

Systems consist of a stand-alone monitor, or a networked array of strategically placed monitoring stations. Each may be operated using AC power, or with a DC / solar recharge system for self-contained operation in remote settings. Data is transmitted via hardwire for integration with user's data acquisition system, such as SCADA, PLC, or data logger. Alternatively wireless data transmission using radio, cellular/GSM, or satellite telemetry is available as required. Please consult with one of our application engineers to discuss your specific system requirements for real-time spill detection and alert.

SPCC & NPDES Compliance & Best Management Practice Tool

~ Typical Users & Applications ~

Power Generators & Distributors

- Fossil Fuel-Oil
- Hydro-Electric
- Nuclear
- Remote Substations

Transportation

- Ports & Harbors
- Marinas & Fuel Docks
- Shipyards
- Airports
- Railways
- Military



Oil / Petrochemical

- Oil Refineries & Blending Plants
- Oil Production Facilities
- Pipelines, Storage & Tank Farms



Offshore Industry

- Platforms & Rigs
- Marine Terminals
- Loading & Transfer Buoys

Industrial / Manufacturing

- Steel & Aluminum
- Pulp & Paper
- Food Oils

Water Quality

- Wastewater Treatment
- Desalination
- Intake Protection

Environmental

- Stormwater & Inland Waterways
- Aquaculture & Fish Farms
- Sensitive Wildlife Habitat

For Application Assistance Please Contact:

+1.858.565.8400 ~ Sales@SlickSleuth.com ~ www.SlickSleuth.com

SYSTEM DESCRIPTION

The **Slick Sleuth™ model SS 200 ADS** is ideal for detection of oil spills and sheens in fresh, brackish, or saltwater environments. It is equally suitable for oil detection over solid substrates such as earth, concrete, metal, etc. The downward looking sensor can be used to detect petroleum products (commonly referred to as Poly Aromatic Hydrocarbons or PAH/BTEX compounds), which include crude oil, bunker "C", diesel/fuel oil, lube oil, turbine oil, hydraulic oil, motor oil, gasoline, jet fuel, etc., as well as various food oils, process oils, and many other oils of concern. Detection is based on the fluorescence of oil using a pulsed UV light source, and Slick Sleuth's proprietary optical photo detector and firmware. The detector automatically filters out ambient conditions ('background noise'), providing highly reliable detection and alarm at the first appearance of oil, day or night, in all light and weather, and regardless of substrate or water surface conditions.

Each detection station is completely self-contained, incorporating a non-contact optical sensor, CPU and electronics, *optional* DC/solar recharge power supply, and *optional* wireless signal telemetry link. All are housed within ruggedized, compact, NEMA 4x weatherproof enclosure(s).

Sensor stations are designed for installation in hazardous (explosive gas) environments, either by the addition of a compatible, positive pressure, instrument-air purge system, or by housing the sensor in an *optional* explosion-proof enclosure. When purchasing Slick Sleuth™ spill detectors, please specify hazardous area classification, in addition to preferred power, communication, and output/interface requirements.

For industrial applications, one or more sensor(s) are strategically placed within and around the facility to protect against either discharge or intake of oil pollution. Sensors are typically co-located with visual and/or audio alarm for local spill notification, as well as signal transmission to the facility's control center for real-time spill alert. Additional *options* are available for spill notification via dedicated computer monitor, telephone, or pager, providing a system tailored to user's specific needs for early warning alert and immediate spill response and containment capabilities.

Slick Sleuth™ provides users with the best available technology, for use as a best management practice (BMP) device and spill prevention and control countermeasure (SPCC) tool.



Each station monitors for oil on a pre-set schedule (user selectable ½ second - 1½ hour interval). Data communication is available via RS232 serial interface, dry contact relay switches, and/or *optional* 4-20mA analog signal output. Integral alarm indicators are also available. Flexible design and user-specified signal output options make integration convenient and straightforward with user's PLC, SCADA, or other customary analog data acquisition systems. Alternatively digital output may be used for serial data communication (typically for stand-alone systems, for example in applications such as harbor monitoring or sensitive habitat protection arrays). Each automated detection station has built-in test capabilities and fault detection, constantly reporting sensor status and health to the base station computer or local control center.

Slick Sleuth™ Utility Software is used to interface with the sensor to allow users to customize sensor operation by programming sampling parameters. The simple to use utility tool is only required for communication during installation/initialization, to change user-specified settings, or for troubleshooting purposes. User adjustable settings include: sampling interval, flash rate, baseline measurement, detection offset/threshold, adaptive baseline, operating modes, logging features, etc.

Detection Process: Slick Sleuth™ reliably detects the presence of oil using a high-power light source within the detection station. UV light is used to 'excite' the target area beneath the sensor. The collimated light beam is filtered to provide maximum stimulation of the target area. The resulting fluorescence from any oil present passes through the sensor's proprietary optical system, and is detected using photo-diodes within the detection station. Whenever oil is present, the monitor immediately signals detection, and automatically actuates (on or off) external mechanisms such as remote alarms, valves, and/or pumps, according to installation logic/design.

Screen capture of utility software. Simple point and click user interface allows operator to program sampling frequency and operating mode to optimize settings for specific application or user requirements

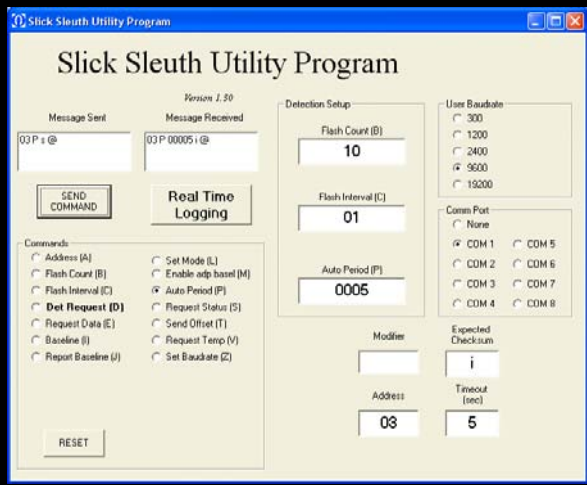

General arrangement for installation of Slick Sleuth sensors on offshore loading buoy (SBM CALM Buoy is depicted here). One to four sensors are installed per buoy. Real-time spill detection is monitored remotely at shore facility, and/or aboard tanker or support vessel, via data telemetry link.

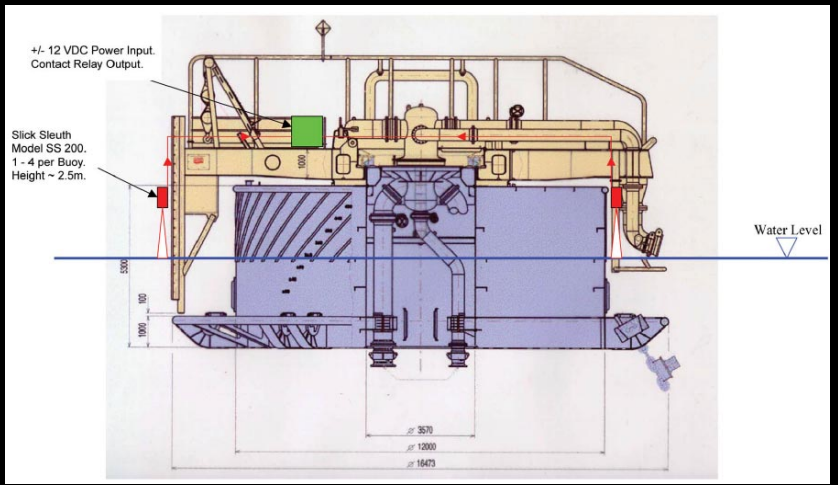

INDUSTRIAL APPLICATIONS



Slick Sleuth™ model SS 200 ADS installed over a deep sump pit. Output is used to control effluent discharge pumps. If oil is detected, the pumps are automatically disabled and the control center is notified so that the situation can be investigated and remedied. This is a typical example for installation at an industrial site, and also representative of control logic for automated spill containment.

Photo courtesy Entergy



SS 200 ADS installed over grated stormwater sump. Sensor output is used to control sump pump, and to notify the control center in case of spill detection. System is powered with AC, and outputs (sources) 4-20mA current loop. Sensor operates normally and is able to detect oil despite partial optical blockage by the grate.

Photos courtesy Dominion

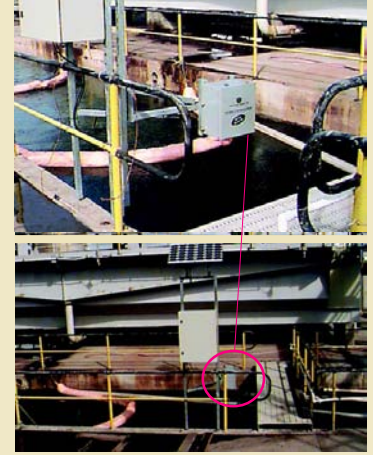

SS 200 ADS installed over refinery cooling water discharge channel. Solar panels and rechargeable batteries are used to power this particular system. Scaled 4-20mA output is monitored at control center for real-time spill detection and status/event logging.

Photos courtesy Shell Oil

PORTS & HARBORS ~ SYSTEM ARRAYS

Slick Sleuth™ sensor (model SS 200 RDS) arrays typically are comprised of a complete stand-alone system (as opposed to industrial-type applications where sensors are integrated into facility's existing process control system). For applications where a networked system of Remote Detection Stations (RDS) is used, up to 99 monitors report to and are controlled by a base station. The base station consists of a dedicated Windows PC running Slick Sleuth™ Base Station Software, which polls each of the remote spill monitoring sensor locations and controls the wireless network. Slick Sleuth™ Software is used for all interface functions, including graphic and tabular display, audio alarm (*optional*), and data logging functions. Software provides 2-way communication with each remote detection station, built-in system diagnostics, output *options* such as auto-dial spill alert (telephone or pager notification), and data/alarm accessibility via computer network or the internet.

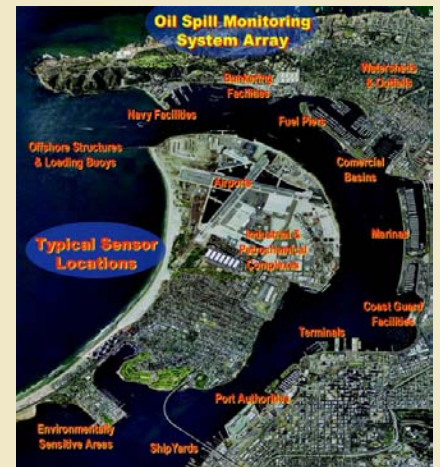

Screen capture of Base Station Software. For use with stand-alone systems such as harbor monitoring array. Provides two-way control of sensors & real-time data and spill notification

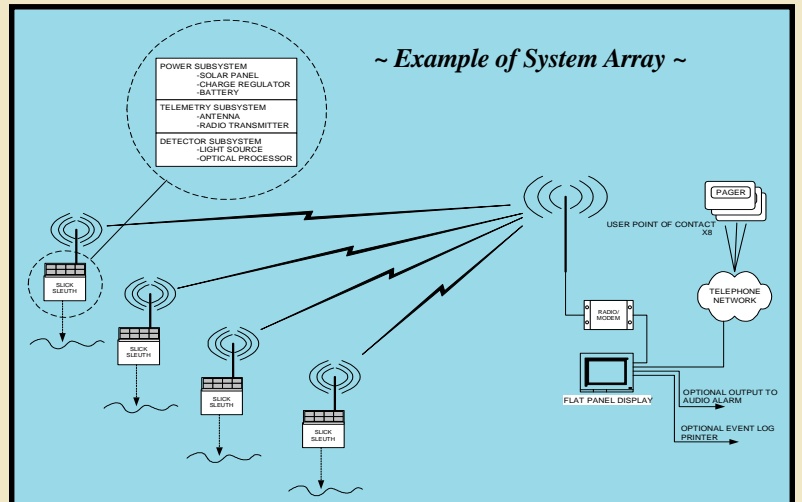
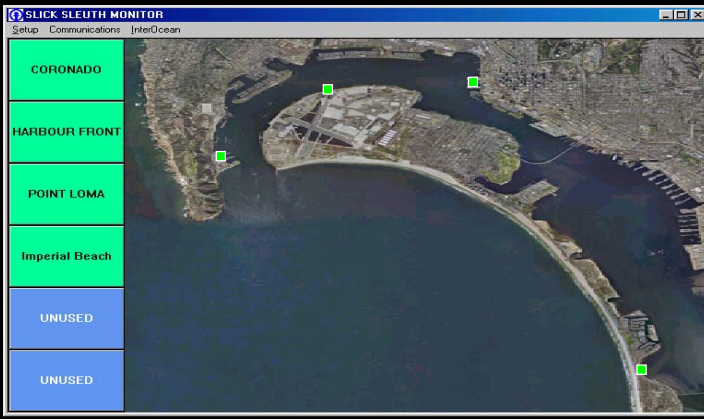



OIL SPILL MONITOR & ALARM

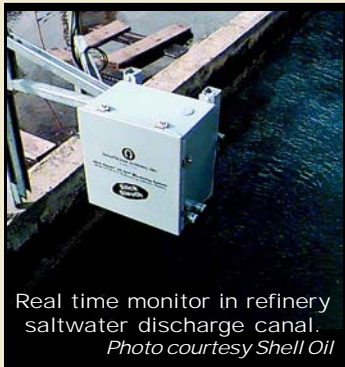

Real time monitor in refinery saltwater discharge canal.
Photo courtesy Shell Oil



Sensor installed to monitor stormwater drainage ditch.
Photo courtesy Occidental



Detector installed above discharge retention area.
Photo courtesy Occidental

~ Specifications ~

Model:	SS 200 ADS - R2 (relay output) - 4-20 (current loop)	
Sensor Operation:	Optical non-contact sensor for detection of oils and hydrocarbon-based fluids. For example: crude oils, bunker "c", hydraulic oils, lube oils, motor oils, turbine oils, jet fuel, process oils, edible (food) oils, and many more (please inquire about specific oils of concern). Method based on detection of fluorescing components (e.g. PAHs) contained in oils. Discrete (yes/no) signal output or scaled output	
Sensitivity:	+/- 3 micron sheen	
Range:	0.2 M to 5 M height above surface target (sensor to be installed above high-water level)	
Operating Temp:	- 10° C to + 60° C (lower/higher temp options available)	
Enclosure:	NEMA 4X, IP 66, weatherproof housing. Painted steel (standard) or stainless steel (optional). 4 corner legs suitable for installing sensor above target area. External ports: Power input, signal output, RS232 serial interface. Pre-fitted for use with purge system approved for use in Class 1, Division 2 hazardous zones	
Dimensions:	20cm x 30cm x 38cm	
Weight:	approx. 13 kg	
Power Options:	100/110/120/220/230/240 VAC. 50/60 Hz 24 VDC (+/- 12V). Solar power option available for remote self-powered installations	
Power Usage:	1.5 Watt typ. (DC) / 15 Watt typ. (AC).	
UV Light Source:	Zenon flash. Collimated, conical, UV light transmission	
Flash Life:	Min. 2 years at highest sampling frequency (2 Hz)	
Output:	Relay Contacts (standard) RS232 (standard) 4-20 mA (as required)	DPDT (oil detect / no detect), SPDT (status) Serial connection via PC or laptop 0-1000 ohms. Sink or Source (default). Accuracy: +/- 2%. Repeatability: +/- 2% Included with wireless package option
	RS485 (optional) Wireless (optional) Audio Alarm (optional) Local Indicators (optional)	See below Audio spill alert Integral light panel indicating: oil, no oil, sensor status
Wireless Options:	Spread Spectrum Radio GSM / Cellular Iridium Satellite	(consult w/application engineer for details) (consult w/application engineer for details) (consult w/application engineer for details)
User Interface:	Slick Sleuth™ Utility Software (installed on user's laptop or PC). Communication via sensor's RS232 port and user's PC/laptop serial port. Direct connection only necessary for initialization during installation, and for troubleshooting. User adjustable settings include: Sampling rate, flash interval/rate, baseline, offset/threshold, operating mode, adaptive baseline, data logging features, etc.	
Base Station:	OPTIONAL Base station only required for "polled" systems. (please consult with IOS engineer)	
Certifications:	1) Conforms to US EPA Standards (in accordance with EPA/530/UST-90/009). 2) CE mark	
Warranty:	1-year InterOcean factory warranty, standard. Supported worldwide.	

~ Installation Drawing ~

